

- 1
- 2
- 3
- 4
- 5
- 6
- 7
- 8
- 9
- 10
- 11
- 12
- 13
- 14
- 15
- 16
- 17
- 18
- 19

MATERIAL

Cast aluminium with epoxy resin coating, matte finish.

CENTRE CAP

Glass-fibre reinforced polyamide-based (PA) technopolymer, colour light grey.

STANDARD EXECUTIONS

H7 reamed hole.

- **GN 923-B-A**: without handle.
- **GN 923-B-R**: with revolving handle in polyamide based (PA) technopolymer, black colour, matte finish.

Hole and keyway in compliance with DIN 6885/1 (see page A-16)**non tradotto**

- **GN 923-K-A**: without handle.
- **GN 923-K-R**: with revolving handle in polyamide based (PA) technopolymer, black colour, matte finish.

Colour index:

- **SW**: RAL 9005 black colour.
- **SR**: RAL 9006 light grey colour.

ACCESSORIES ON REQUEST

Axial retaining washer GN 184 (see page 677).

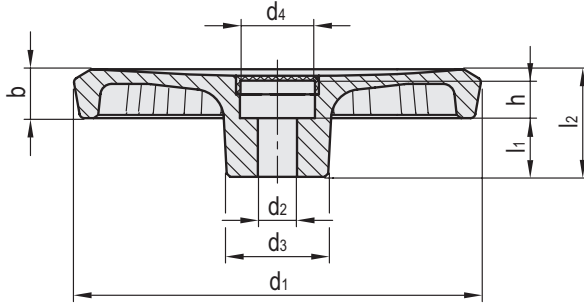

Conversion Table	
1 mm = 0,039 inch	
D	
mm	inch
50	1.95
80	3.12
100	3.90
125	4.88
140	5.46
160	6.24
200	7.80

GN 923-B-A

METRIC

Code	Description	d1	d2 H7	d3	d4	b	h	l1	l2	Washer	⚖️
GN.68271	GN 923-80-B10-A-SW	80	10	26	17	13	7	16	26	GN 184-16	101
GN.68270	GN 923-80-B10-A-SR	80	10	26	17	13	7	16	26	GN 184-16	101
GN.68273	GN 923-80-B12-A-SW	80	12	26	17	13	7	16	26	GN 184-16	100
GN.68272	GN 923-80-B12-A-SR	80	12	26	17	13	7	16	26	GN 184-16	100
GN.68275	GN 923-100-B10-A-SW	100	10	28	22	14	9.5	17	30	GN 184-20	153
GN.68274	GN 923-100-B10-A-SR	100	10	28	22	14	9.5	17	30	GN 184-20	153
GN.68277	GN 923-100-B12-A-SW	100	12	28	22	14	9.5	17	30	GN 184-20	150
GN.68276	GN 923-100-B12-A-SR	100	12	28	22	14	9.5	17	30	GN 184-20	150
GN.68279	GN 923-125-B12-A-SW	125	12	31	22	15	11	18	33	GN 184-20	253
GN.68278	GN 923-125-B12-A-SR	125	12	31	22	15	11	18	33	GN 184-20	253
GN.68281	GN 923-125-B14-A-SW	125	14	31	22	15	11	18	33	GN 184-20	261
GN.68280	GN 923-125-B14-A-SR	125	14	31	22	15	11	18	33	GN 184-20	261
GN.68283	GN 923-140-B14-A-SW	140	14	36	28.5	16.5	13	19	36	GN 184-25	338
GN.68282	GN 923-140-B14-A-SR	140	14	36	28.5	16.5	13	19	36	GN 184-25	338
GN.68285	GN 923-140-B16-A-SW	140	16	36	28.5	16.5	13	19	36	GN 184-25	333
GN.68284	GN 923-140-B16-A-SR	140	16	36	28.5	16.5	13	19	36	GN 184-25	333
GN.68287	GN 923-160-B14-A-SW	160	14	36	28.5	18	14.5	20	39	GN 184-25	432
GN.68286	GN 923-160-B14-A-SR	160	14	36	28.5	18	14.5	20	39	GN 184-25	432
GN.68289	GN 923-160-B16-A-SW	160	16	36	28.5	18	14.5	20	39	GN 184-25	450
GN.68288	GN 923-160-B16-A-SR	160	16	36	28.5	18	14.5	20	39	GN 184-25	450
GN.68291	GN 923-200-B18-A-SW	200	18	42	36	20.5	16	24	45	GN 184-32	780
GN.68290	GN 923-200-B18-A-SR	200	18	42	36	20.5	16	24	45	GN 184-32	780
GN.68293	GN 923-200-B20-A-SW	200	20	42	36	20.5	16	24	45	GN 184-32	765
GN.68292	GN 923-200-B20-A-SR	200	20	42	36	20.5	16	24	45	GN 184-32	765

Handwheels and crank handles

Conversion Table	
1 mm = 0.039 inch	
D	
mm	inch
50	1.95
80	3.12
100	3.90
125	4.88
140	5.46
160	6.24
200	7.80

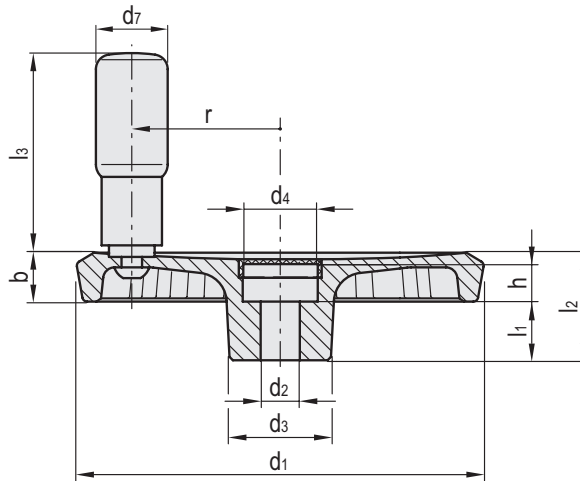

GN 923-B-R

METRIC

Code	Description	d1	d2 H7	d3	d4	b	h	l1	l2	l3	r	d7	Washer	⚖
GN.68295	GN 923-80-B10-R-SW	80	10	26	17	13	7	16	26	43.5	27.5	16	GN 184-16	120
GN.68294	GN 923-80-B10-R-SR	80	10	26	17	13	7	16	26	43.5	27.5	16	GN 184-16	120
GN.68297	GN 923-80-B12-R-SW	80	12	26	17	13	7	16	26	43.5	27.5	16	GN 184-16	100
GN.68296	GN 923-80-B12-R-SR	80	12	26	17	13	7	16	26	43.5	27.5	16	GN 184-16	100
GN.68299	GN 923-100-B10-R-SW	100	10	28	22	14	9.5	17	30	58	36	18	GN 184-20	180
GN.68298	GN 923-100-B10-R-SR	100	10	28	22	14	9.5	17	30	58	36	18	GN 184-20	180
GN.68301	GN 923-100-B12-R-SW	100	12	28	22	14	9.5	17	30	58	36	18	GN 184-20	300
GN.68300	GN 923-100-B12-R-SR	100	12	28	22	14	9.5	17	30	58	36	18	GN 184-20	300
GN.68303	GN 923-125-B12-R-SW	125	12	31	22	15	11	18	33	61	45.5	22	GN 184-20	340
GN.68302	GN 923-125-B12-R-SR	125	12	31	22	15	11	18	33	61	45.5	22	GN 184-20	340
GN.68305	GN 923-125-B14-R-SW	125	14	31	22	15	11	18	33	61	45.5	22	GN 184-20	339
GN.68304	GN 923-125-B14-R-SR	125	14	31	22	15	11	18	33	61	45.5	22	GN 184-20	339
GN.68307	GN 923-140-B14-R-SW	140	14	36	28.5	16.5	13	19	36	76	52	24	GN 184-25	420
GN.68306	GN 923-140-B14-R-SR	140	14	36	28.5	16.5	13	19	36	76	52	24	GN 184-25	420
GN.68309	GN 923-140-B16-R-SW	140	16	36	28.5	16.5	13	19	36	76	52	24	GN 184-25	382
GN.68308	GN 923-140-B16-R-SR	140	16	36	28.5	16.5	13	19	36	76	52	24	GN 184-25	382
GN.68311	GN 923-160-B14-R-SW	160	14	36	28.5	18	14.5	20	39	76	61	24	GN 184-25	543
GN.68310	GN 923-160-B14-R-SR	160	14	36	28.5	18	14.5	20	39	76	61	24	GN 184-25	543
GN.68313	GN 923-160-B16-R-SW	160	16	36	28.5	18	14.5	20	39	76	61	24	GN 184-25	540
GN.68312	GN 923-160-B16-R-SR	160	16	36	28.5	18	14.5	20	39	76	61	24	GN 184-25	540
GN.68315	GN 923-200-B18-R-SW	200	18	42	36	20.5	16	24	45	85	77.5	25	GN 184-32	880
GN.68314	GN 923-200-B18-R-SR	200	18	42	36	20.5	16	24	45	85	77.5	25	GN 184-32	880
GN.68317	GN 923-200-B20-R-SW	200	20	42	36	20.5	16	24	45	85	77.5	25	GN 184-32	889
GN.68316	GN 923-200-B20-R-SR	200	20	42	36	20.5	16	24	45	85	77.5	25	GN 184-32	889

- 1
- 2
- 3
- 4
- 5
- 6
- 7
- 8
- 9
- 10
- 11
- 12
- 13
- 14
- 15
- 16
- 17
- 18
- 19

Handwheels and crank handles

- 1
- 2
- 3
- 4
- 5
- 6
- 7
- 8
- 9
- 10
- 11
- 12
- 13
- 14
- 15
- 16
- 17
- 18
- 19

Conversion Table
1 mm = 0.039 inch

D	
mm	inch
50	1.95
80	3.12
100	3.90
125	4.88
140	5.46
160	6.24
200	7.80

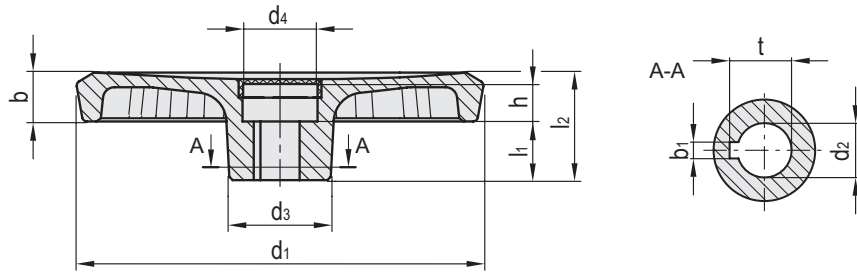

METRIC

GN 923-K-A

Code	Description	d1	d2 H7	d3	d4	b	b1	h	l1	l2	t	Washer	
GN.68322	GN 923-50-K6-A-SW	50	6	20	13	13	2	7	16	26	7.1	GN 184-12	66
GN.68321	GN 923-50-K6-A-SR	50	6	20	13	13	2	7	16	26	7.1	GN 184-12	66
GN.68326	GN 923-50-K8-A-SW	50	8	20	13	13	2	7	16	26	9.1	GN 184-12	65
GN.68325	GN 923-50-K8-A-SR	50	8	20	13	13	2	7	16	26	9.1	GN 184-12	65
GN.68332	GN 923-80-K10-A-SW	80	10	26	17	13	3	7	16	26	11.4	GN 184-16	101
GN.68331	GN 923-80-K10-A-SR	80	10	26	17	13	3	7	16	26	11.4	GN 184-16	101
GN.68336	GN 923-80-K12-A-SW	80	12	26	17	13	4	7	16	26	13.8	GN 184-16	100
GN.68335	GN 923-80-K12-A-SR	80	12	26	17	13	4	7	16	26	13.8	GN 184-16	100
GN.70302	GN 923-100-K10-A-SW	100	10	28	22	14	3	9.5	17	30	11.4	GN 184-20	153
GN.70301	GN 923-100-K10-A-SR	100	10	28	22	14	3	9.5	17	30	11.4	GN 184-20	153
GN.70306	GN 923-100-K12-A-SW	100	12	28	22	14	4	9.5	17	30	13.8	GN 184-20	150
GN.70305	GN 923-100-K12-A-SR	100	12	28	22	14	4	9.5	17	30	13.8	GN 184-20	150
GN.70322	GN 923-125-K12-A-SW	125	12	31	22	15	4	11	18	33	13.8	GN 184-20	253
GN.70321	GN 923-125-K12-A-SR	125	12	31	22	15	4	11	18	33	13.8	GN 184-20	253
GN.70326	GN 923-125-K14-A-SW	125	14	31	22	15	5	11	18	33	16.3	GN 184-20	261
GN.70325	GN 923-125-K14-A-SR	125	14	31	22	15	5	11	18	33	16.3	GN 184-20	261
GN.70342	GN 923-140-K14-A-SW	140	14	36	28.5	16.5	5	13	19	36	16.3	GN 184-25	338
GN.70341	GN 923-140-K14-A-SR	140	14	36	28.5	16.5	5	13	19	36	16.3	GN 184-25	338
GN.70346	GN 923-140-K16-A-SW	140	16	36	28.5	16.5	5	13	19	36	18.3	GN 184-25	333
GN.70345	GN 923-140-K16-A-SR	140	16	36	28.5	16.5	5	13	19	36	18.3	GN 184-25	333
GN.70362	GN 923-160-K14-A-SW	160	14	36	28.5	18	5	14.5	20	39	16.3	GN 184-25	432
GN.70361	GN 923-160-K14-A-SR	160	14	36	28.5	18	5	14.5	20	39	16.3	GN 184-25	432
GN.70366	GN 923-160-K16-A-SW	160	16	36	28.5	18	5	14.5	20	39	18.3	GN 184-25	450
GN.70365	GN 923-160-K16-A-SR	160	16	36	28.5	18	5	14.5	20	39	18.3	GN 184-25	450
GN.70382	GN 923-200-K18-A-SW	200	18	42	36	20.5	6	16	24	45	20.8	GN 184-32	780
GN.70381	GN 923-200-K18-A-SR	200	18	42	36	20.5	6	16	24	45	20.8	GN 184-32	780
GN.70386	GN 923-200-K20-A-SW	200	20	42	36	20.5	6	16	24	45	22.8	GN 184-32	765
GN.70385	GN 923-200-K20-A-SR	200	20	42	36	20.5	6	16	24	45	22.8	GN 184-32	765

Handwheels and crank handles

Conversion Table	
1 mm = 0.039 inch	
D	
mm	inch
50	1.95
80	3.12
100	3.90
125	4.88
140	5.46
160	6.24
200	7.80

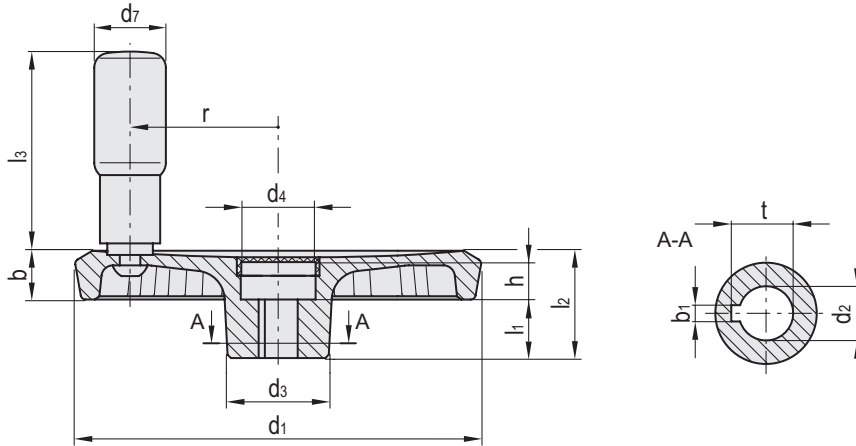

GN 923-K-R

METRIC

Code	Description	d1	d2 H7	d3	d4	b	b1	h	l1	l2	l3	r	d7	t	Washer	
GN.68324	GN 923-50-K6-R-SW	50	6	20	13	13	2	7	16	26	20	16	13	7.1	GN 184-12	77
GN.68323	GN 923-50-K6-R-SR	50	6	20	13	13	2	7	16	26	20	16	13	7.1	GN 184-12	77
GN.68328	GN 923-50-K8-R-SW	50	8	20	13	13	2	7	16	26	20	16	13	9.1	GN 184-12	76
GN.68327	GN 923-50-K8-R-SR	50	8	20	13	13	2	7	16	26	20	16	13	9.1	GN 184-12	76
GN.68334	GN 923-80-K10-R-SW	80	10	26	17	13	3	7	16	26	43.5	27.5	16	11.4	GN 184-16	120
GN.68333	GN 923-80-K10-R-SR	80	10	26	17	13	3	7	16	26	43.5	27.5	16	11.4	GN 184-16	120
GN.68338	GN 923-80-K12-R-SW	80	12	26	17	13	4	7	16	26	43.5	27.5	16	13.8	GN 184-16	100
GN.68337	GN 923-80-K12-R-SR	80	12	26	17	13	4	7	16	26	43.5	27.5	16	13.8	GN 184-16	100
GN.70304	GN 923-100-K10-R-SW	100	10	28	22	14	3	9.5	17	30	58	36	18	11.4	GN 184-20	180
GN.70303	GN 923-100-K10-R-SR	100	10	28	22	14	3	9.5	17	30	58	36	18	11.4	GN 184-20	180
GN.70308	GN 923-100-K12-R-SW	100	12	28	22	14	4	9.5	17	30	58	36	18	13.8	GN 184-20	300
GN.70307	GN 923-100-K12-R-SR	100	12	28	22	14	4	9.5	17	30	58	36	18	13.8	GN 184-20	300
GN.70324	GN 923-125-K12-R-SW	125	12	31	22	15	4	11	18	33	61	45.5	22	13.8	GN 184-20	340
GN.70323	GN 923-125-K12-R-SR	125	12	31	22	15	4	11	18	33	61	45.5	22	13.8	GN 184-20	340
GN.70328	GN 923-125-K14-R-SW	125	14	31	22	15	5	11	18	33	61	45.5	22	16.3	GN 184-20	339
GN.70327	GN 923-125-K14-R-SR	125	14	31	22	15	5	11	18	33	61	45.5	22	16.3	GN 184-20	339
GN.70344	GN 923-140-K14-R-SW	140	14	36	28.5	16.5	5	13	19	36	76	52	24	16.3	GN 184-25	420
GN.70343	GN 923-140-K14-R-SR	140	14	36	28.5	16.5	5	13	19	36	76	52	24	16.3	GN 184-25	420
GN.70348	GN 923-140-K16-R-SW	140	16	36	28.5	16.5	5	13	19	36	76	52	24	18.3	GN 184-25	382
GN.70347	GN 923-140-K16-R-SR	140	16	36	28.5	16.5	5	13	19	36	76	52	24	18.3	GN 184-25	382
GN.70364	GN 923-160-K14-R-SW	160	14	36	28.5	18	5	14.5	20	39	76	61	24	16.3	GN 184-25	543
GN.70363	GN 923-160-K14-R-SR	160	14	36	28.5	18	5	14.5	20	39	76	61	24	16.3	GN 184-25	543
GN.70368	GN 923-160-K16-R-SW	160	16	36	28.5	18	5	14.5	20	39	76	61	24	18.3	GN 184-25	540
GN.70367	GN 923-160-K16-R-SR	160	16	36	28.5	18	5	14.5	20	39	76	61	24	18.3	GN 184-25	540
GN.70384	GN 923-200-K18-R-SW	200	18	42	36	20.5	6	16	24	45	85	77.5	25	20.8	GN 184-32	880
GN.70383	GN 923-200-K18-R-SR	200	18	42	36	20.5	6	16	24	45	85	77.5	25	20.8	GN 184-32	880
GN.70388	GN 923-200-K20-R-SW	200	20	42	36	20.5	6	16	24	45	85	77.5	25	22.8	GN 184-32	889
GN.70387	GN 923-200-K20-R-SR	200	20	42	36	20.5	6	16	24	45	85	77.5	25	22.8	GN 184-32	889



Handwheels and crank handles